

Guide units EAGF, for electric cylinders

FESTO

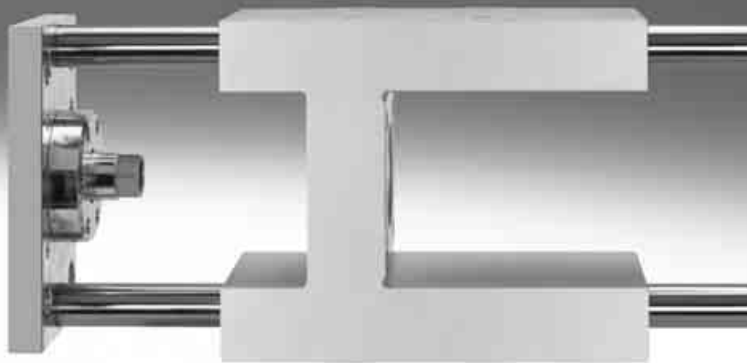

Festo core product range
Covers 80% of your automation tasks

Worldwide:

Always in stock

Superb:

Festo quality at an attractive price

Easy:

Reduces procurement and storing complexity

★ Ready for dispatch from the Festo factory in 24 hours
Held in stock in 13 service centres worldwide
More than 2200 products

★ Ready for dispatch in 5 days maximum from stock
Assembled for you in 4 service centres worldwide
Up to 6 x 10¹² variants per product series

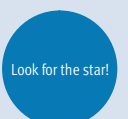

Guide units EAGF, for electric cylinders

Key features

At a glance

The guide unit EAGF is used to protect electric cylinders against torsion when these are subjected to high torque loads.

It offers high precision guiding for workpiece handling and other applications.

The interface enables quick and easy installation on many Festo drives/axes.

For electric cylinder ESBF → page 4



For electric cylinder EPCO → page 14



Sample applications

Pick & place with two guide units

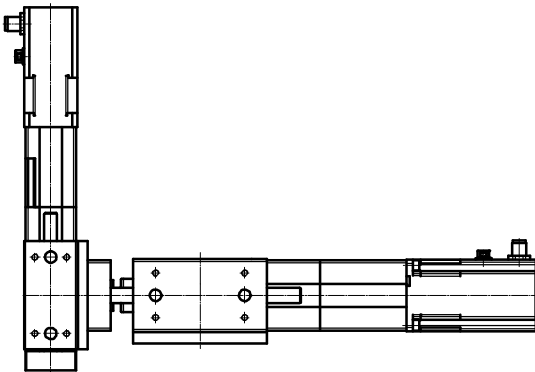

Pick & place with guide unit and linear axis

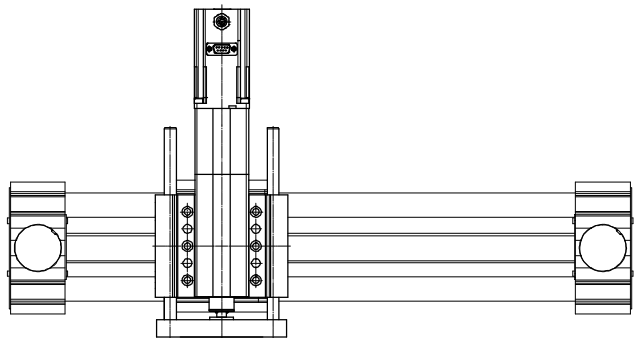

Guide units EAGF, for electric cylinders ESBF

Type codes

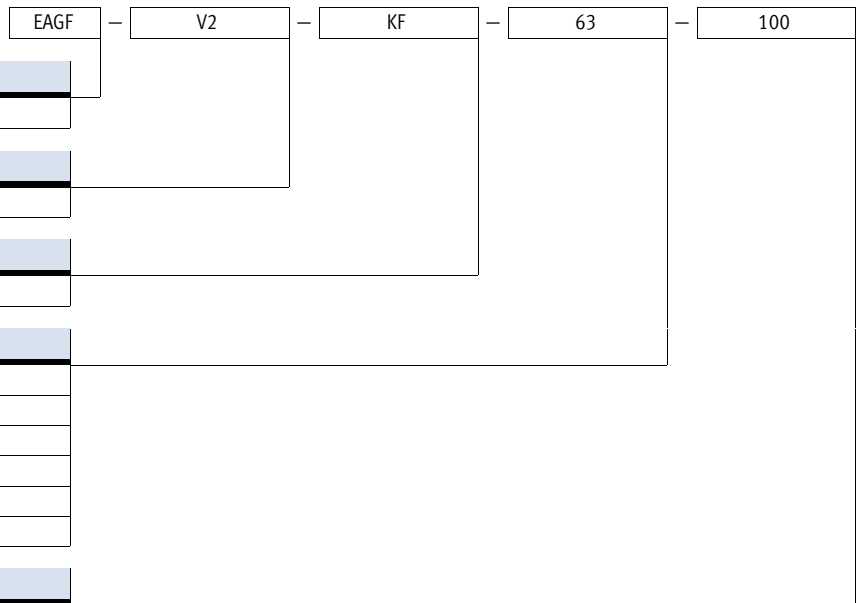

Guide units EAGF, for electric cylinders ESBF

Technical data

⌀ - Diameter
32 ... 100 mm

 www.festo.com

┆ - Stroke length
1 ... 550 mm



General technical data						
Size	32	40	50	63	80	100
Stroke [mm]	1 ... 500				1 ... 550	
Design	Guide					
Guidance	Recirculating ball bearing guide					
Displacement force [N]	15				40	
Reversing backlash [µm]	0					
Type of mounting	Via female thread					
Mounting position	Any					
Ambient temperature [°C]	-20 ... +80 °C					

Weight [g] (for calculation example → page 6)						
Size	32	40	50	63	80	100
Basic weight with 0 mm stroke	1685	2517	4059	5525	10517	13263
Additional weight per 10 mm stroke	18	32	49	49	76	76
Moving mass with 0 mm stroke	724	1283	2015	2560	5166	6148
Additional mass per 10 mm stroke	18	32	49	49	76	76

Centre of gravity of the moving mass [mm] (for calculation example → page 6)						
Size	32	40	50	63	80	100
With 0 mm stroke	30	38	46	48	54	47
Supplement per 10 mm stroke	4.1	4.2	4.3	4.1	3.8	3.6

Materials

Sectional view

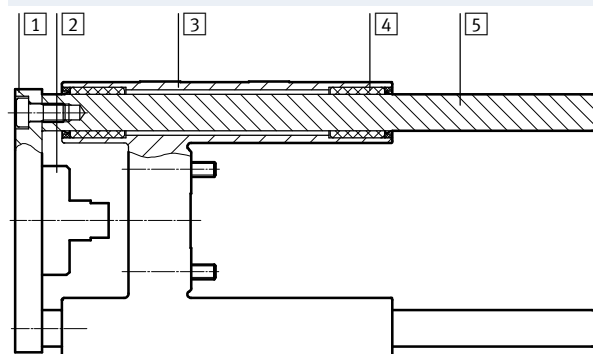

Guide unit		
1	Yoke plate	Steel
2	Compensating component	Steel
3	Housing	Anodised wrought aluminium alloy
4	Bearing	Steel
5	Guide rod	Steel
-	Note on materials	RoHS compliant Free of copper and PTFE

Guide units EAGF, for electric cylinders ESBF

Technical data

Characteristic load values

The indicated forces and torques refer to the guide centre.

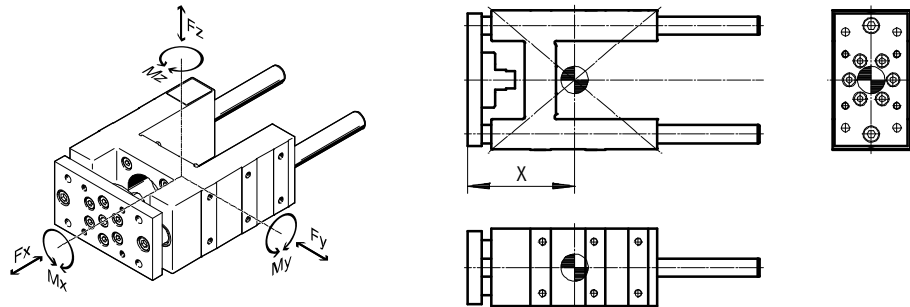

If the guide unit is subjected to two or more of the indicated forces and torques simultaneously, the following equation must be satisfied in addition to the indicated maximum loads:

Calculating the load comparison factor:

$$f_v = \frac{|F_y|}{F_{y,max}} + \frac{|F_z|}{F_{z,max}} + \frac{|M_x|}{M_{x,max}} + \frac{|M_y|}{M_{y,max}} + \frac{|M_z|}{M_{z,max}} \leq 1$$

Distance X (for calculation example → page 6)

Size		32	40	50	63	80	100
Dimension X	[mm]	83	85	99	117	142	145

Max. permissible forces and torques

Size		32	40	50	63	80	100
Static							
F _{y,max.} /F _{z,max.}	[N]	1020	1260	1600	1600	3120	3120
M _{x,max.}	[Nm]	38	55	83	95	231	268
M _{y,max.)/M_{z,max.}}	[Nm]	46	65	89	115	259	267
Dynamic (for a service life of 5000 km)							
F _{y,max.)/F_{z,max.}}	[N]	750	1000	1260	1260	2300	2300
M _{x,max.}	[Nm]	28	44	65	75	170	198
M _{y,max.)/M_{z,max.}}	[Nm]	34	52	70	90	191	197

Guide units EAGF, for electric cylinders ESBF

Technical data

Calculating the service life

The service life of the guide depends on the load. To provide a rough indication of the service life of the guide,

the graph below plots the load comparison factor f_v against the service life ratio q .

These values are only theoretical. You must consult your local Festo contact for load comparison factors f_v greater than 1.5.

Load comparison factor f_v as a function of service life ratio q

Example:

The effect on the service life, deviating from the specified reference service

life, can be determined by means of the service life ratio q :

Given:

Reference service life = 5000 km

Required service life = 3000 km

$$q = \frac{3000\text{km}}{5000\text{km}} = 0.6$$

The graph gives a load comparison factor f_v of 1.2. This means that the permissible resultant load can be utilised up to 120%.

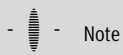
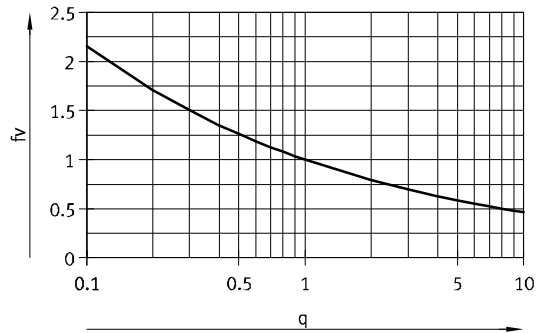

Note

PositioningDrives
engineering software
www.festo.com

$f_v > 1.5$ are only theoretical comparison values.

Calculation example

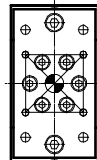
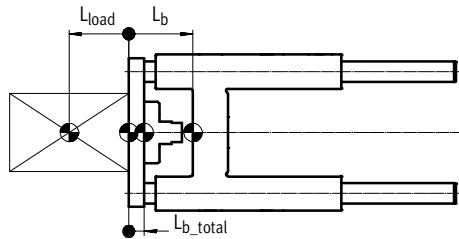

L_b = Centre of gravity of the moving mass of the guide unit

L_{load} = Centre of gravity of the payload

L_{b_total} = Centre of gravity of the total moving mass

Length measurements should be provided with plus/minus signs as shown in the figure:

$L_{b_total} > 0$ = Centre of gravity of the moving mass is on the payload side

$L_{b_total} < 0$ = Centre of gravity of the moving mass is on the guide side

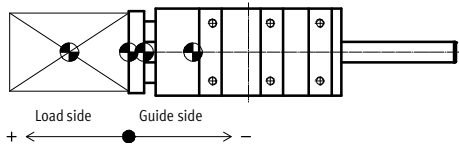

Given:

- Guide unit: EAGF-V2-KF-32-200
- Stroke length $H = 200$ mm
- Centre of gravity of payload $L_{load} = 15$ mm
- Payload: $m_{load} = 5$ kg
- Acceleration: $a_x = a_y = 2 \text{ m/s}^2$, $a_z = 0 \text{ m/s}^2$

To be calculated:

- Loads F_{y_dyn}/F_{z_dyn} and $M_{x_dyn}/M_{y_dyn}/M_{z_dyn}$
- Verification of operation with combined load
- Expected service life

Guide units EAGF, for electric cylinders ESBF

Technical data

Calculation example

Solution:

Moving load:

$$m_{b_total} = m_b + m_{load} \quad (m_b = m_{0b} + H \times m_{Hb})$$

From table → page 4

$$m_{0b} = 0.724 \text{ kg}$$

$$m_{Hb} = 0.018 \text{ kg/10 mm}$$

$$m_b = 0.724 \text{ kg} + 200 \text{ mm} \times 0.018 \text{ kg/10 mm} = 1.084 \text{ kg}$$

$$m_{b_total} = 1.084 \text{ kg} + 5 \text{ kg} = 6.084 \text{ kg}$$

m_b = Moving mass of the guide unit

m_{0b} = Moving mass with 0 mm stroke

m_{Hb} = Additional mass per 10 mm stroke

H = Stroke length

Centre of gravity of the moving mass

$$L_{b_total} = \frac{L_{load} \times m_{load} + L_b \times m_b}{m_{b_total}} \quad (L_b = L_{0b} + H \times L_{Hb})$$

From table → page 4

$$L_{0b} = 30 \text{ mm}$$

$$L_{Hb} = 4.1 \text{ mm/10 mm}$$

$$L_b = 30 \text{ mm} + 200 \text{ mm} \times 4.1 \text{ mm/10 mm} = 112 \text{ mm}$$

$$L_{b_total} = \frac{(+ 15 \text{ mm}) \times 5 \text{ kg} + (- 112 \text{ mm}) \times 1.084 \text{ kg}}{6.084 \text{ kg}} = - 8 \text{ mm}$$

L_b = Centre of gravity of the moving mass of the guide unit

m_b = Moving mass of the guide unit

L_{load} = Centre of gravity of the payload

m_{load} = Payload

L_{0b} = Centre of gravity of the moving mass with 0 mm stroke

L_{Hb} = Additional centre of gravity of the moving mass per 10 mm stroke

Length measurements should be provided with plus/minus signs as shown in the figure:

$L_{b_total} > 0$ = Centre of gravity of the moving mass is on the payload side

$L_{b_total} < 0$ = Centre of gravity of the moving mass is on the guide side

Loads F_{y_dyn}/F_{z_dyn} and $M_{x_dyn}/M_{y_dyn}/M_{z_dyn}$

$$F_{y_dyn} = m_{b_total} \times a_y = 6.084 \text{ kg} \times 2 \text{ m/s}^2 = 12 \text{ N}$$

$$F_{z_dyn} = m_{b_total} \times (g + a_z) = 6.084 \text{ kg} \times (9.81 \text{ m/s}^2 + 0 \text{ m/s}^2) = 60 \text{ N}$$

From table → page 5

Dimension X = 83 mm

$$M_{y_dyn} = F_{z_dyn} \times (\text{dimension X} + \text{stroke} + L_{b_total}) = 60 \text{ N} \times (83 \text{ mm} + 200 \text{ mm} + (-8 \text{ mm})) = 16 \text{ Nm}$$

$$M_{z_dyn} = F_{y_dyn} \times (\text{dimension X} + \text{stroke} + L_{b_total}) = 12 \text{ N} \times (83 \text{ mm} + 200 \text{ mm} + (-8 \text{ mm})) = 3 \text{ Nm}$$

Verification of operation with combined load

Max values from table → page 5

$$F_{y_max} = 750 \text{ N} \quad M_{x_max} = 28 \text{ Nm}$$

$$F_{z_max} = 750 \text{ N} \quad M_{y_max} = 34 \text{ Nm}$$

$$M_{z_max} = 34 \text{ Nm}$$

$$f_v = \frac{|F_y|}{F_{y,max}} + \frac{|F_z|}{F_{z,max}} + \frac{|M_x|}{M_{x,max}} + \frac{|M_y|}{M_{y,max}} + \frac{|M_z|}{M_{z,max}} \leq 1$$

$$f_v = \frac{12 \text{ N}}{750 \text{ N}} + \frac{60 \text{ N}}{750 \text{ N}} + \frac{0 \text{ Nm}}{28 \text{ Nm}} + \frac{16 \text{ Nm}}{34 \text{ Nm}} + \frac{3 \text{ Nm}}{34 \text{ Nm}} = 0.7 \leq 1$$

Expected service life

$$L_{calc} = \frac{L_{ref}}{f_v^3} = \frac{5000 \text{ km}}{0.7^3} = 14000 \text{ km}$$

Guide units EAGF, for electric cylinders ESBF

Technical data



Max. payload F and torque M as a function of cantilever load A

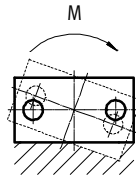
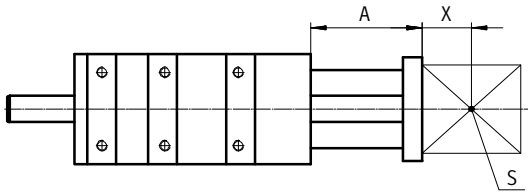

- A = Cantilever load
- X = Distance to centre of gravity of the payload
- S = Centre of gravity of the payload
- M = Torque

Explanation of how to read the graphs in the case of a combined load

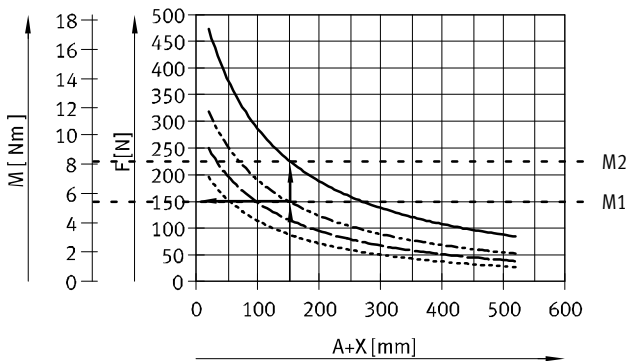

- Determine cantilever load (150 mm)
- Enter lateral force (150 N)
- Enter distance from curve
- Permitted torque is the difference between M2 and M1

- Running performance of 500 km
- - - Running performance of 2500 km
- Running performance of 5000 km
- - - Running performance of 10000 km

Size 32

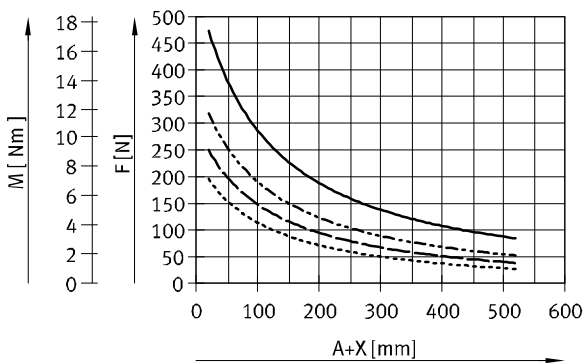

Size 40

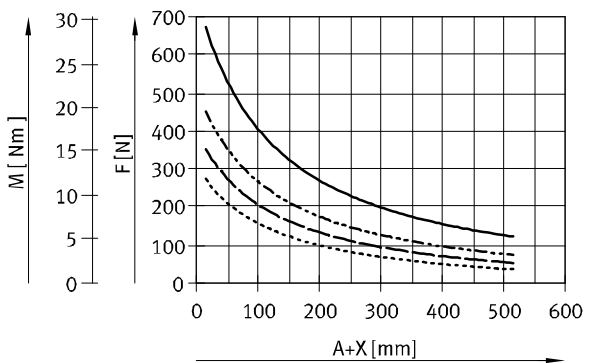

- Running performance of 500 km
- - - Running performance of 2500 km
- Running performance of 5000 km
- - - Running performance of 10000 km

Guide units EAGF, for electric cylinders ESBF

Technical data

Max. payload F and torque M as a function of cantilever load A

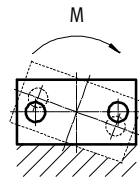
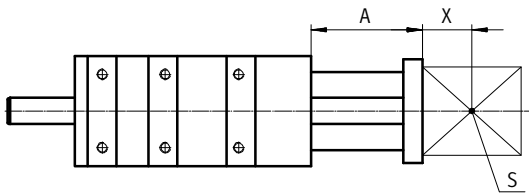

A = Cantilever load
 X = Distance to centre of gravity of the payload
 S = Centre of gravity of the payload
 M = Torque

Size 50

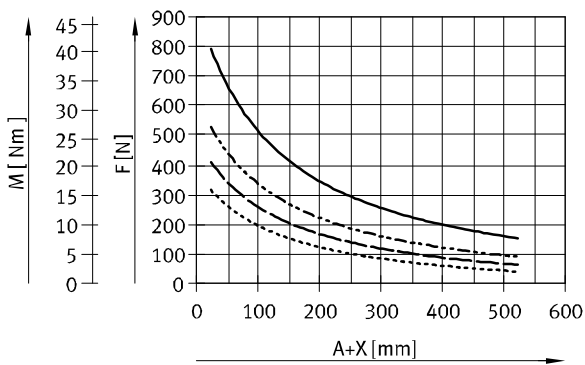

Size 63

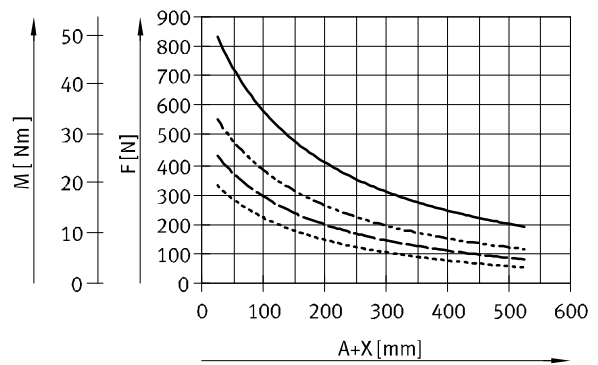

Size 80

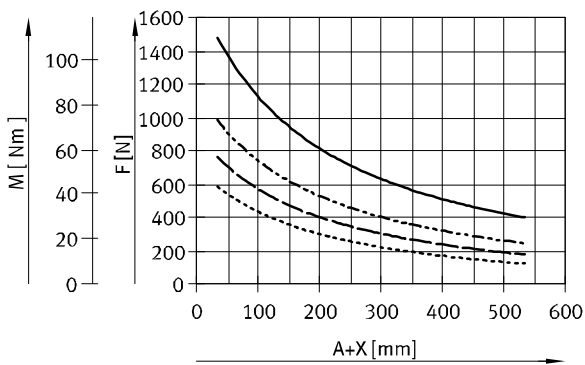

Size 100

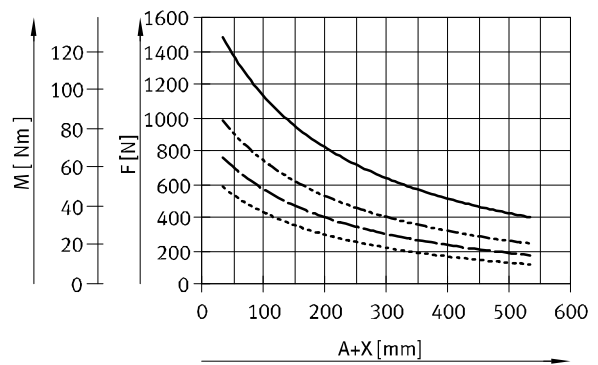

- Running performance of 500 km
- - - Running performance of 2500 km
- · - Running performance of 5000 km
- · · Running performance of 10000 km

Guide units EAGF, for electric cylinders ESBF

Technical data

Deflection f_{tare} (due to tare weight) as a function of cantilever load A

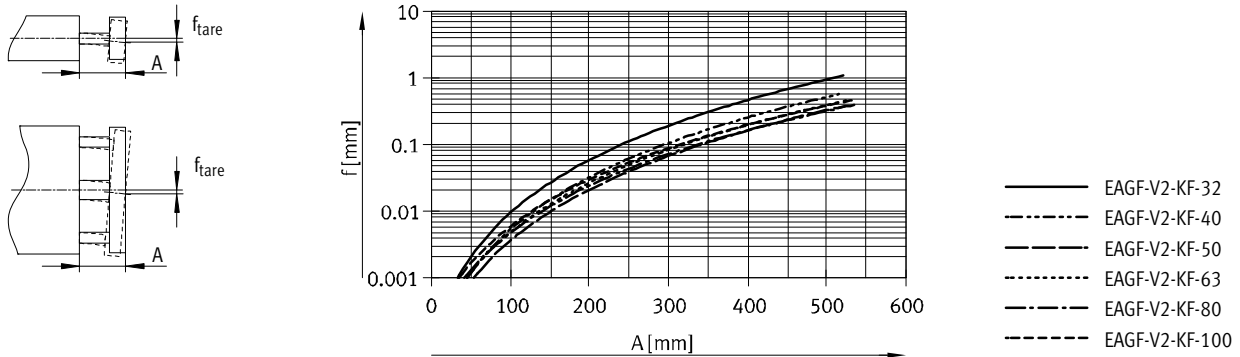

Deflection $f_{standard}$ (due to lateral force) as a function of cantilever load A

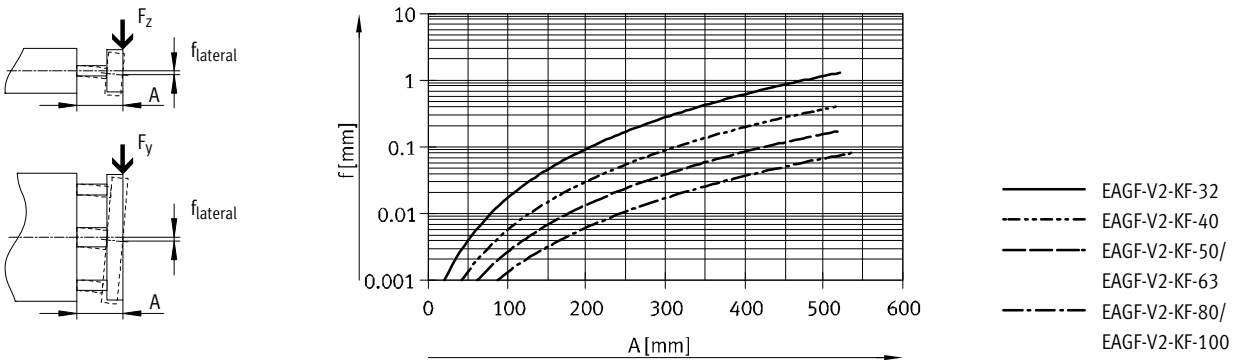

The maximum permissible lateral force must not be exceeded.

$$f_{lateral} = \frac{F_{lateral}}{F_{standard}} \times f_{standard}$$

$F_{standard} = 10 \text{ N}$

- A = Cantilever load of guide rod
- $f_{lateral}$ = Deflection due to lateral force
- $F_{lateral}$ = Lateral force
- $F_{standard}$ = Standardised lateral force
- $f_{standard}$ = Deflection due to standardised lateral force (value from graph)

Inclination α (due to torque) as a function of cantilever load A

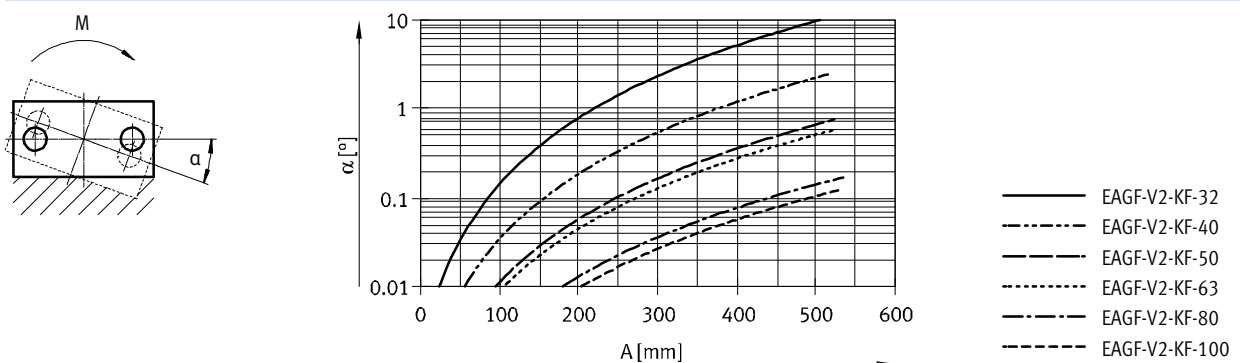

$$\alpha = \frac{M}{M_{standard}} \times \alpha_{standard}$$

$M_{standard} = 2 \text{ Nm}$
(valid for $\alpha \leq 10^\circ$)

- A = Cantilever load of guide rod
- α = Inclination due to torque
- M = Torque
- $M_{standard}$ = Standardised torque
- $\alpha_{standard}$ = Deflection due to standardised torque

Guide units EAGF, for electric cylinders ESBF

Technical data

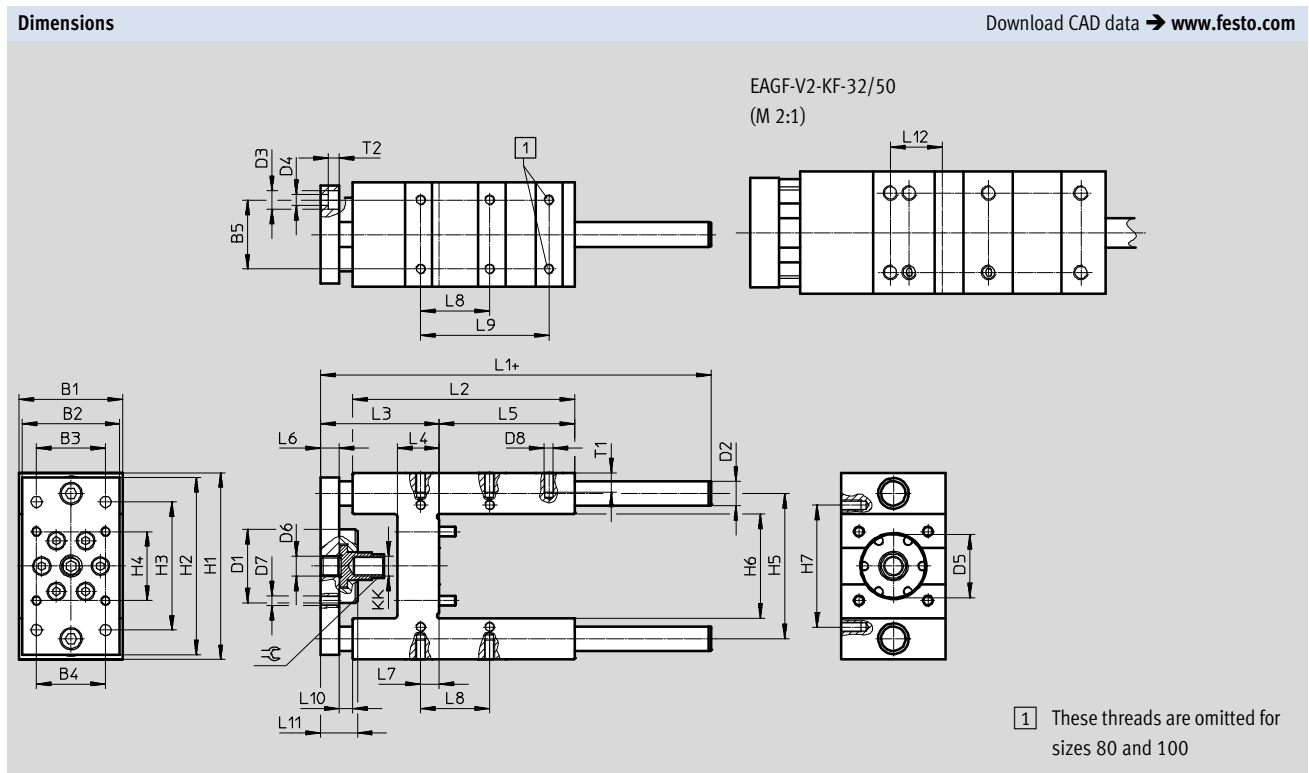

Size	B1	B2	B3	B4	B5	D1	D2	D3	D4	D5	D6	D7
	-0.3		±0.2	±0.2	±0.2	∅	∅ H6	∅	∅	∅ H8		
32	50	45	32.5	32.5	32.5	44	12	11	6.6	34	M6	M6
40	58	54	38	38	38	48	16	11	6.6	39	M8	M6
50	70	63	46.5	46.5	46.5	60	20	15	9	45	M8	M8
63	85	80	56.5	56.5	56.5	60	20	15	9	52	M16	M8
80	105	100	72	72	72	78	25	18	11	60	M18	M10
100	130	120	89	89	89	78	25	18	11	70	M18	M10

Size	D8	H1	H2	H3	H4	H5	H6	H7	KK	L1	L2
		-0.5		±0.2	±0.2	±0.2		±0.2		±1	
32	M6	97	90	78	32.5	74	50.5±0.3	61	M10x1.25	154.8	125
40	M6	115	110	84	38	87	58.5±0.3	69	M12x1.25	172.8	140
50	M8	137	130	100	46.5	104	70.5±0.3	85	M16x1.5	187.8	150
63	M8	152	145	105	56.5	119	85.5±0.3	100	M16x1.5	219.8	182
80	M10	189	180	130	72	148	106+1/-0.6	130	M20x1.5	257.8	215
100	M10	213	200	150	89	172	131+1/-0.6	150	M20x1.5	262.8	220

Size	L3	L4	L5	L6	L7	L8	L9	L10	L11	L12	T1	T2	≈C1
						±0.2	±0.2						
32	69.5 ⁺⁵	24	76	12	4.3	32.5	78	-	24	12	14	6.5	15
40	74.5 ⁺⁵	28	81	15	11	38	84	-	27	-	14	6.5	15
50	94.5 ⁺⁵	34	79	15	18.8	46.5	100	-	30	37	16	9	19
63	96.6	34	111	15	15.3	56.5	105	11	30	-	16	9	19
80	121.6	40	128	20	21	72	-	15	39	-	20	11	27
100	126.6	40	128	20	24.5	89	-	15	39	-	20	11	27

Guide units EAGF, for electric cylinders ESBF

FESTO

Technical data

★ Core product range

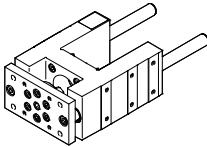
Ordering data				
Guide unit	Size	Stroke [mm]	Part No.	Type
	32	100	★ 2782679	EAGF-V2-KF-32-100
		200	★ 2782818	EAGF-V2-KF-32-200
		320	★ 2782885	EAGF-V2-KF-32-320
		400	★ 2782923	EAGF-V2-KF-32-400
	40	100	★ 2782939	EAGF-V2-KF-40-100
		200	★ 2782976	EAGF-V2-KF-40-200
		320	★ 2783047	EAGF-V2-KF-40-320
		400	★ 2783080	EAGF-V2-KF-40-400
	50	100	★ 2783639	EAGF-V2-KF-50-100
		200	★ 2784152	EAGF-V2-KF-50-200
		320	★ 2784164	EAGF-V2-KF-50-320
		400	★ 2784184	EAGF-V2-KF-50-400
	63	100	★ 1725842	EAGF-V2-KF-63-100
		200	★ 1725843	EAGF-V2-KF-63-200
		320	★ 1725844	EAGF-V2-KF-63-320
		400	★ 1725845	EAGF-V2-KF-63-400

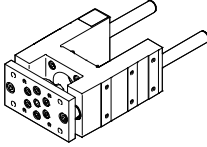
Ordering data					
Guide unit	Size	Stroke [mm]	Part No.	Type	
	32	1 ... 500	3038083	EAGF-V2-KF-32-	
	40	1 ... 500	3038089	EAGF-V2-KF-40-	
	50	1 ... 500	3038094	EAGF-V2-KF-50-	
	63	1 ... 500	2608521	EAGF-V2-KF-63-	
	80	100		1725846	EAGF-V2-KF-80-100
		200		1725847	EAGF-V2-KF-80-200
		320		1725848	EAGF-V2-KF-80-320
		400		1725849	EAGF-V2-KF-80-400
		1 ... 500		2608528	EAGF-V2-KF-80-
	100	100		1725850	EAGF-V2-KF-100-100
		200		1725851	EAGF-V2-KF-100-200
		320		1725852	EAGF-V2-KF-100-320
		400		1725853	EAGF-V2-KF-100-400
		1 ... 500		2608532	EAGF-V2-KF-100-

Festo core product range

- ★ Ready for dispatch from the Festo factory in 24 hours
- ★ Ready for dispatch in 5 days maximum from stock

Guide units EAGF, for electric cylinders EPCO

Type codes



EAGF – P1 – KF – 16 – 100

Type	
EAGF	Guide unit

Designation	
P1	For electric cylinder EPCO

Guidance	
KF	Recirculating ball bearing guide

Size	
16	16 mm
25	25 mm
40	40 mm

Stroke [mm]	
50	50 mm
75	75 mm
100	100 mm
125	125 mm
150	150 mm
175	175 mm
200	200 mm
250	250 mm
300	300 mm
350	350 mm
400	400 mm

Guide units EAGF, for electric cylinders EPCO

Technical data

⊘ Diameter
16, 25, 40 mm

 www.festo.com

┆ Stroke length
50 ... 400 mm



General technical data				
Size		16	25	40
Stroke	[mm]	50, 75, 100, 125, 150, 175, 200	50, 75, 100, 125, 150, 175, 200, 250, 300	50, 75, 100, 125, 150, 175, 200, 250, 300, 350, 400
Design		Guide		
Guidance		Recirculating ball bearing guide		
Displacement force	[N]	3.2	4	6
Reversing backlash	[μm]	0		
Permissible speed	[m/s]	1		
Permissible acceleration	[m/s ²]	25		
Type of mounting		Via female thread		
Mounting position		Any		

Operating and environmental conditions				
Size		16	25	40
Ambient temperature	[°C]	0 ... +50		
Storage temperature	[°C]	-20 ... +60		
Relative air humidity		0 ... 95 (non-condensing)		
Degree of protection		IP40		
Corrosion resistance class CRC ¹⁾		1		

1) Corrosion resistance class CRC 1 to Festo standard FN 940070
Low corrosion stress. For dry indoor applications or transport and storage protection. Also applies to parts behind covers, in the non-visible interior area, and parts which are covered in the application (e.g. drive trunnions).

Weight [g] (for calculation → page 16)				
Size		16	25	40
Basic weight with 0 mm stroke		600	1080	1910
Additional weight per 10 mm stroke		8	12	18
Moving mass with 0 mm stroke		160	300	560
Additional mass per 10 mm stroke		8	12	18

Centre of gravity of the moving mass [mm] (for calculation → page 16)				
Size		16	25	40
With 0 mm stroke		29	30	36
Supplement per 10 mm stroke		4.5	4.5	4.5

Guide units EAGF, for electric cylinders EPCO

Technical data

Materials

Sectional view

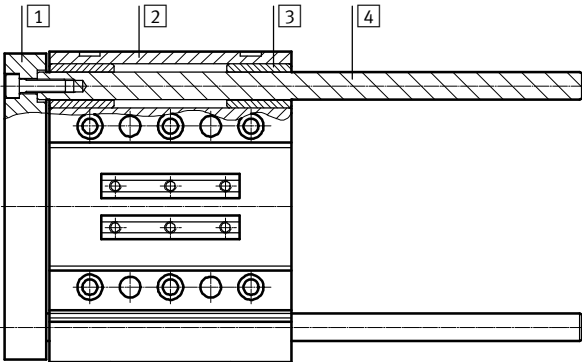

Guide unit

1	Yoke plate	Anodised wrought aluminium alloy
2	Housing	Anodised wrought aluminium alloy
3	Bearing	Steel
4	Guide rod	Hard-chromium plated tempered steel
-	Note on materials	RoHS compliant Free of copper and PTFE

Characteristic load values

The indicated forces and torques refer to the guide centre.

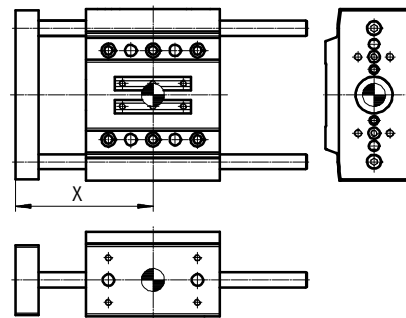
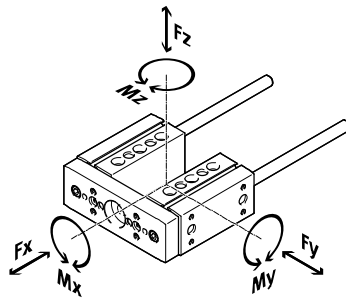

If the guide unit is subjected to two or more of the indicated forces and torques simultaneously, the following equation must be satisfied in addition to the indicated maximum loads:

Calculating the load comparison factor:

$$f_v = \frac{|F_y|}{F_{y,max}} + \frac{|F_z|}{F_{z,max}} + \frac{|M_x|}{M_{x,max}} + \frac{|M_y|}{M_{y,max}} + \frac{|M_z|}{M_{z,max}} \leq 1$$

Distance X (for calculation → page 16)

Size	16	25	40
Dimension X [mm]	51	59	72

Max. permissible forces and torques

Size	16	25	40
Static			
$F_{y,max.}/F_{z,max.}$ [N]	355	415	510
$M_{x,max.}$ [Nm]	13	19	27
$M_{y,max.}/M_{z,max.}$ [Nm]	9	12	20
Dynamic (for a service life of 5000 km)			
$F_{y,max.}/F_{z,max.}$ [N]	160	320	380
$M_{x,max.}$ [Nm]	6	15	20
$M_{y,max.}/M_{z,max.}$ [Nm]	4	10	15

Guide units EAGF, for electric cylinders EPCO

Technical data

Calculating the service life

The service life of the guide depends on the load. To provide a rough indication of the service life of the guide,

the graph below plots the load comparison factor f_v against the service life ratio q .

These values are only theoretical. You must consult your local Festo contact for load comparison factors f_v greater than 1.5.

Load comparison factor f_v as a function of service life ratio q

Example:

The effect on the service life, deviating from the specified reference service

life, can be determined by means of the service life ratio q :

Given:

Reference service life = 5000 km

Required service life = 3000 km

$$q = \frac{3000\text{km}}{5000\text{km}} = 0.6$$

The graph gives a load comparison factor f_v of 1.2. This means that the permissible resultant load can be utilised up to 120%.

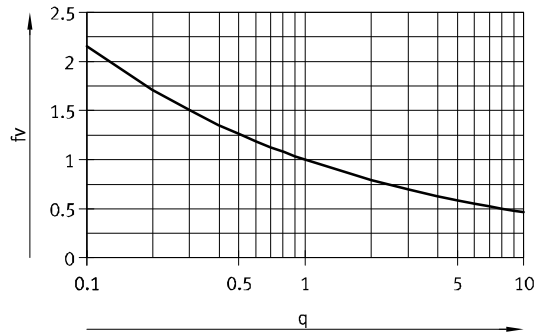

Note

PositioningDrives
engineering software
www.festo.com

$f_v > 1.5$ are only theoretical comparison values.

Calculation example

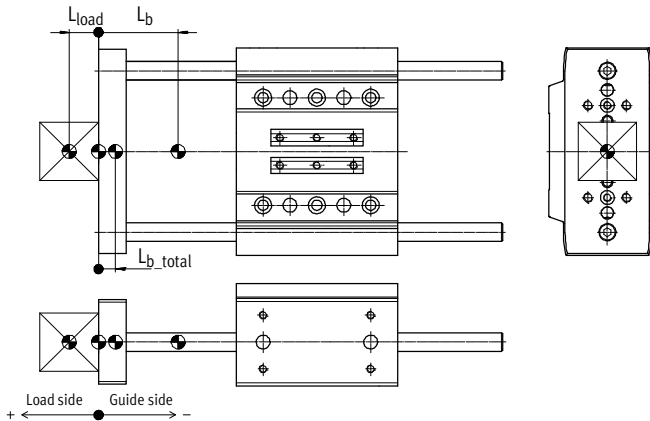

L_b = Centre of gravity of the moving mass of the guide unit

L_{load} = Centre of gravity of the payload

L_{b_total} = Centre of gravity of the total moving mass

Length measurements should be provided with plus/minus signs as shown in the figure:

$L_{b_total} > 0$ = Centre of gravity of the moving mass is on the payload side

$L_{b_total} < 0$ = Centre of gravity of the moving mass is on the guide side

Given:

- Guide unit: EAGF-P1-KF-25-200
- Stroke length: $H = 200$ mm
- Centre of gravity of payload $L_{load} = 15$ mm
- Payload: $m_{load} = 2$ kg
- Acceleration: $a_x = a_y = 2$ m/s², $a_z = 0$ m/s²

To be calculated:

- Loads F_{y_dyn}/F_{z_dyn} and $M_{x_dyn}/M_{y_dyn}/M_{z_dyn}$
- Verification of operation with combined load
- Expected service life

Guide units EAGF, for electric cylinders EPCO

Technical data

Calculation example

Solution:

Moving load:

$$m_{b_total} = m_b + m_{load} \quad (m_b = m_{0b} + H \times m_{Hb})$$

From table → page 14

$$m_{0b} = 0.3 \text{ kg}$$

$$m_{Hb} = 0.012 \text{ kg/10 mm}$$

$$m_b = 0.3 \text{ kg} + 200 \text{ mm} \times 0.012 \text{ kg/10 mm} = 0.54 \text{ kg}$$

$$m_{b_total} = 0.54 \text{ kg} + 2 \text{ kg} = 2.54 \text{ kg}$$

m_b = Moving mass of the guide unit

m_{0b} = Moving mass with 0 mm stroke

m_{Hb} = Additional mass per 10 mm stroke

H = Stroke length

Centre of gravity of the moving mass

$$L_{b_total} = \frac{L_{load} \times m_{load} + L_b \times m_b}{m_{b_total}} \quad (L_b = L_{0b} + H \times L_{Hb})$$

From table → page 14

$$L_{0b} = 30 \text{ mm}$$

$$L_{Hb} = 4.5 \text{ mm/10 mm}$$

$$L_b = 30 \text{ mm} + 200 \text{ mm} \times 4.5 \text{ mm/10 mm} = 120 \text{ mm}$$

$$L_{b_total} = \frac{(+ 15 \text{ mm}) \times 2 \text{ kg} + (- 120 \text{ mm}) \times 0.54 \text{ kg}}{2.54 \text{ kg}} = - 14 \text{ mm}$$

L_b = Centre of gravity of the moving mass of the guide unit

m_b = Moving mass of the guide unit

L_{load} = Centre of gravity of the payload

m_{load} = Payload

L_{0b} = Centre of gravity of the moving mass with 0 mm stroke

L_{Hb} = Additional centre of gravity of the moving mass per 10 mm stroke

Length measurements should be provided with plus/minus signs as shown in the figure:

$L_{b_total} > 0$ = Centre of gravity of the moving mass is on the payload side

$L_{b_total} < 0$ = Centre of gravity of the moving mass is on the guide side

Loads F_{y_dyn}/F_{z_dyn} and $M_{x_dyn}/M_{y_dyn}/M_{z_dyn}$

$$F_{y_dyn} = m_{b_total} \times a_y = 2.54 \text{ kg} \times 2 \text{ m/s}^2 = 5 \text{ N}$$

$$F_{z_dyn} = m_{b_total} \times (g + a_z) = 2.54 \text{ kg} \times (9.81 \text{ m/s}^2 + 0 \text{ m/s}^2) = 25 \text{ N}$$

From table → page 15

Dimension X = 59 mm

$$M_{y_dyn} = F_{z_dyn} \times (\text{dimension X} + \text{stroke} + L_{b_total}) = 25 \text{ N} \times (59 \text{ mm} + 200 \text{ mm} + (-14 \text{ mm})) = 6.1 \text{ Nm}$$

$$M_{z_dyn} = F_{y_dyn} \times (\text{dimension X} + \text{stroke} + L_{b_total}) = 5 \text{ N} \times (59 \text{ mm} + 200 \text{ mm} + (-14 \text{ mm})) = 1.2 \text{ Nm}$$

Verification of operation with combined load

Max values from table → page 15

$$F_{y_max} = 320 \text{ N} \quad M_{x_max} = 15 \text{ Nm}$$

$$F_{z_max} = 320 \text{ N} \quad M_{y_max} = 10 \text{ Nm}$$

$$M_{z_max} = 10 \text{ Nm}$$

$$f_v = \frac{|F_y|}{F_{y,max}} + \frac{|F_z|}{F_{z,max}} + \frac{|M_x|}{M_{x,max}} + \frac{|M_y|}{M_{y,max}} + \frac{|M_z|}{M_{z,max}} \leq 1$$

$$f_v = \frac{5 \text{ N}}{320 \text{ N}} + \frac{25 \text{ N}}{320 \text{ N}} + \frac{0 \text{ Nm}}{15 \text{ Nm}} + \frac{6.1 \text{ Nm}}{10 \text{ Nm}} + \frac{1.2 \text{ Nm}}{10 \text{ Nm}} = 0.8 \leq 1$$

Expected service life

$$L_{calc} = \frac{L_{ref}}{f_v^3} = \frac{5000 \text{ km}}{0.8^3} = 9000 \text{ km}$$

Guide units EAGF, for electric cylinders EPCO

Technical data

FESTO

Max. payload F and torque M as a function of cantilever load A

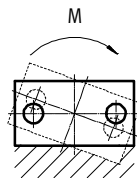
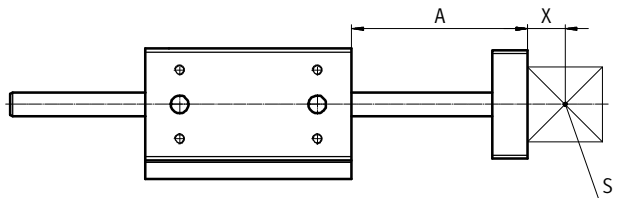

- A = Cantilever load
- X = Distance to centre of gravity of the payload
- S = Centre of gravity of the payload
- M = Torque

Explanation of how to read graphs in the case of a combined load

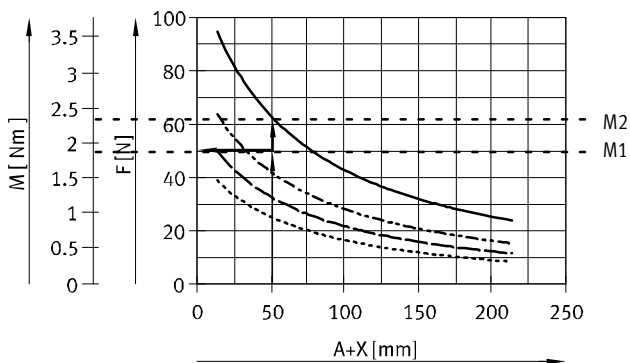

- Determine cantilever load (50 mm)
- Enter lateral force (50 N)
- Enter distance from curve
- Permitted torque is the difference between M2 and M1

- Running performance of 500 km
- - - Running performance of 2500 km
- · - Running performance of 5000 km
- · · Running performance of 10000 km

Size 16

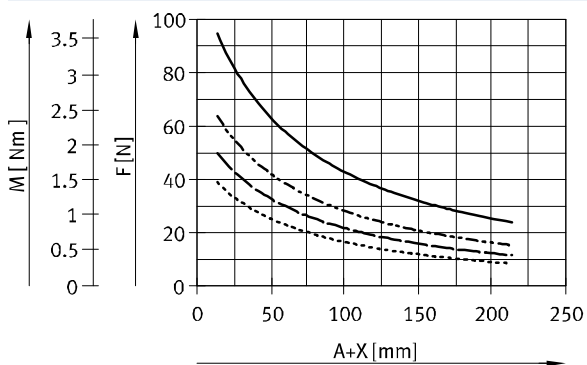

Size 25

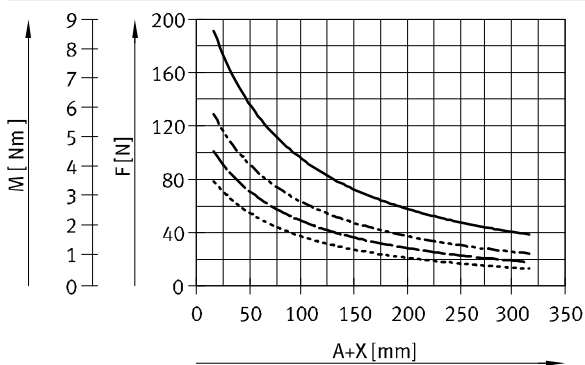

Size 40

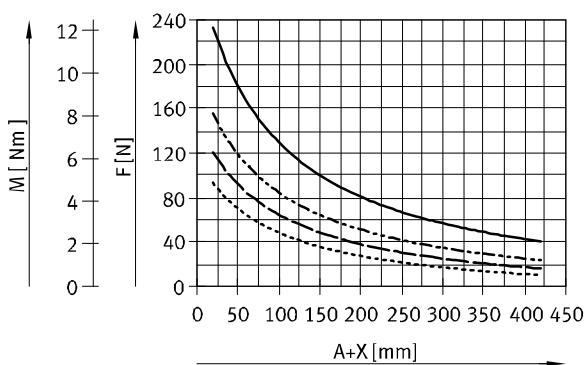

- Running performance of 500 km
- - - Running performance of 2500 km
- · - Running performance of 5000 km
- · · Running performance of 10000 km

Guide units EAGF, for electric cylinders EPCO

Technical data

Deflection f_{tare} (due to tare weight) as a function of cantilever load A

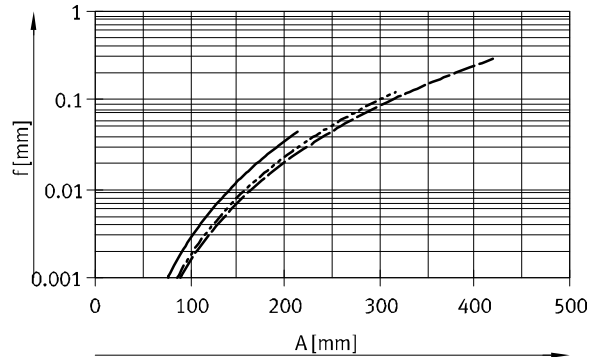
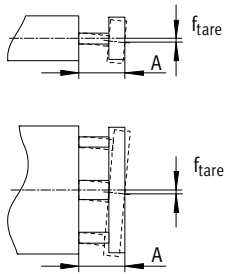

— EAGF-P1-KF-16
 - - - EAGF-P1-KF-25
 - · - EAGF-P1-KF-40

Deflection $f_{standard}$ (due to lateral force) as a function of cantilever load A

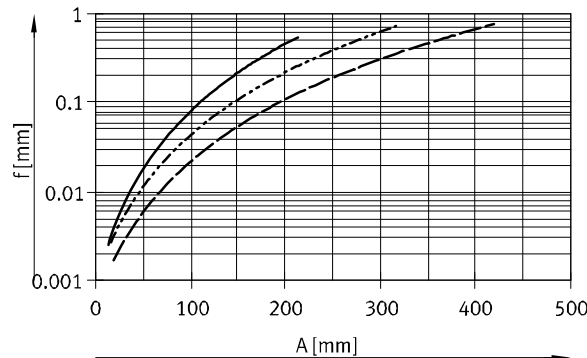
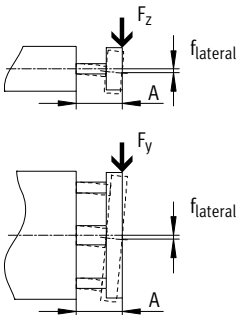

— EAGF-P1-KF-16
 - - - EAGF-P1-KF-25
 - · - EAGF-P1-KF-40

The maximum permissible lateral force must not be exceeded.

$$f_{lateral} = \frac{F_{lateral}}{F_{standard}} \times f_{standard}$$

$F_{standard} = 10 \text{ N}$

A = Cantilever load of guide rod
 $f_{lateral}$ = Deflection due to lateral force
 $F_{lateral}$ = Lateral force
 $F_{standard}$ = Standardised lateral force
 $f_{standard}$ = Deflection due to standardised lateral force (value from graph)

Inclination α (due to torque) as a function of cantilever load A

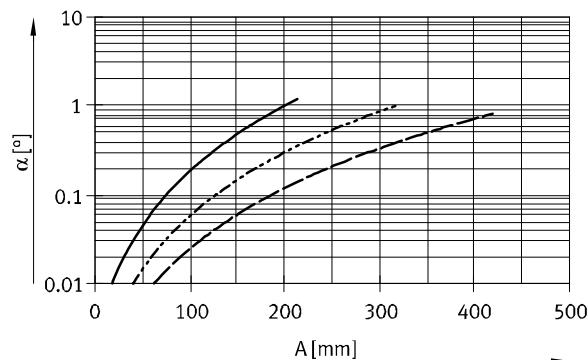
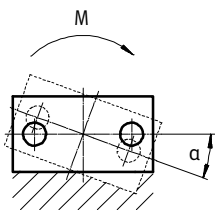

— EAGF-P1-KF-16
 - - - EAGF-P1-KF-25
 - · - EAGF-P1-KF-40

$$\alpha = \frac{M}{M_{standard}} \times \alpha_{standard}$$

$M_{standard} = 2 \text{ Nm}$
 (valid for $\alpha \leq 10^\circ$)

A = Cantilever load of guide rod
 α = Inclination due to torque
 M = Torque
 $M_{standard}$ = Standardised torque
 $\alpha_{standard}$ = Deflection due to standardised torque

Guide units EAGF, for electric cylinders EPCO

Technical data

Possible combinations with other drives/axes via direct mounting

Guide unit EAGF with electric cylinder EPCO and guide unit EAGF

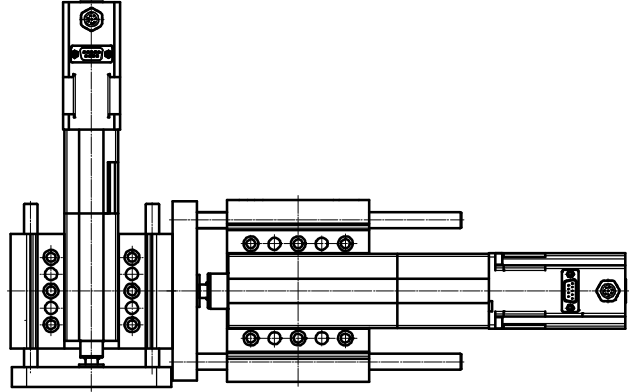
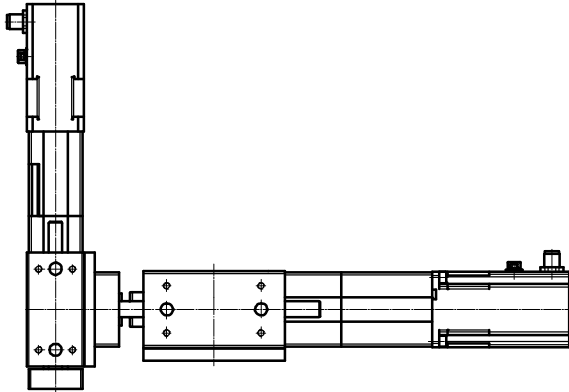

Size	Base axis	
	EAGF-P1-KF-25	EAGF-P1-KF-40
Assembly axis		
EAGF-P1-KF-16	■	-
EAGF-P1-KF-25	-	■

Toothed belt axis ELGR with electric cylinder EPCO and guide unit EAGF

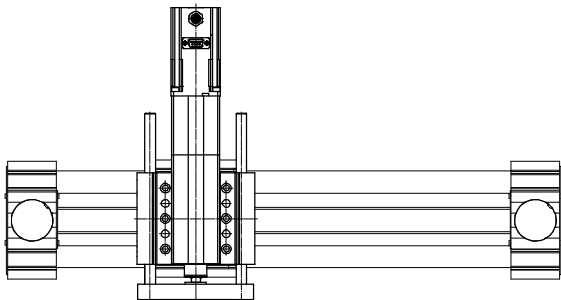

Size	Base axis		
	ELGR-TB-35	ELGR-TB-45	ELGR-TB-55
Assembly axis			
EAGF-P1-KF-16	■	-	-
EAGF-P1-KF-25	-	■	-
EAGF-P1-KF-40	-	-	■

Guide units EAGF, for electric cylinders EPCO

Technical data

Possible combinations with other drives/axes via direct mounting

Rotary drive ERMO with electric cylinder EPCO and guide unit EAGF

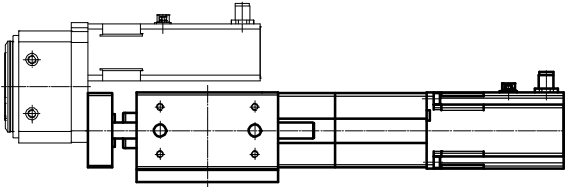

Size	Base axis		
	EAGF-P1-KF-16	EAGF-P1-KF-25	EAGF-P1-KF-40
Assembly axis			
ERMO-12	■	-	-
ERMO-16	-	■	-
ERMO-25	-	-	■

Mini slide DGSL with electric cylinder EPCO and guide unit EAGF

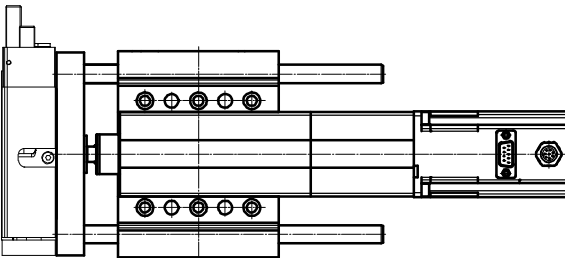

Size	Base axis		
	EAGF-P1-KF-16	EAGF-P1-KF-25	EAGF-P1-KF-40
Assembly axis			
DGSL-8-40 ¹⁾	■	-	-
DGSL-10-30 ¹⁾	-	■	-
DGSL-12-40 ¹⁾	-	-	■

1) Minimal stroke

Guide units EAGF, for electric cylinders EPCO

Technical data

FESTO

Dimensions

Download CAD data → www.festo.com

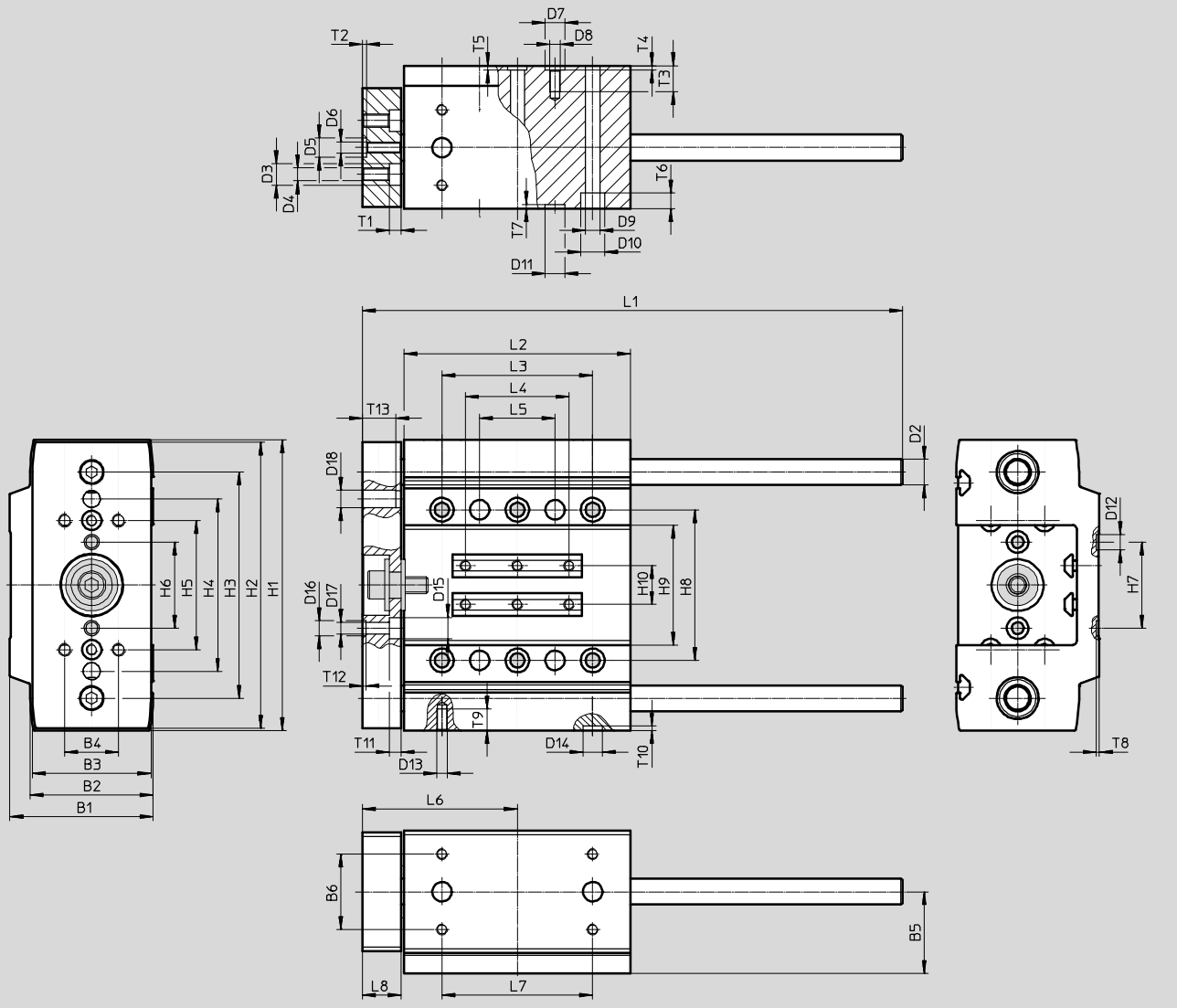

Size 16

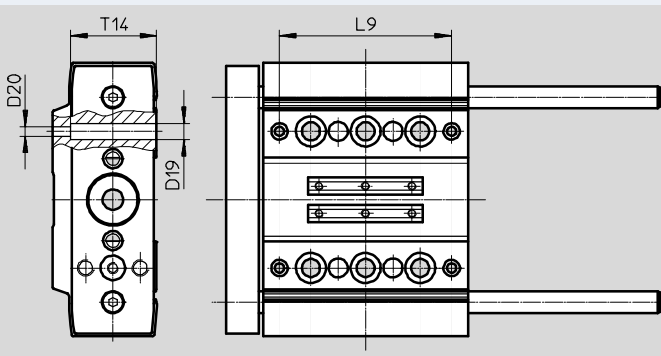

Guide units EAGF, for electric cylinders EPCO

Technical data

Size	B1	B2	B3	B4 ±0.05	B5	B6 ±0.05	D2 ∅ h7	D3 ∅	D4 ∅	D5 ∅ H8	D6	D7 ∅ H8
16	38	32	30	20	22	20	8	–	M6	9	M4	9
25	50	42	40	20	29	25	10	10	M6	9	M4	9
40	66.5	57	55	25	38	35	12	10	M6	9	M5	9

Size	D8	D9 ∅	D10 ∅	D11 ∅ H8	D12 ∅ H8	D13	D14 ∅ H8	D15 ∅	D16 ∅ H8	D17 ∅	D18 ∅ H7	D19 ∅
16	M5	6.6	11	7	7	M5	9	8	7	5 ^{H7}	–	6
25	M5	6.6	11	9	7	M5	9	10	7	5.5	5	–
40	M5	6.6	11	9	7	M5	9	10	7	5.5	8	–

Size	D20 ∅	H1	H2	H3	H4 ±0.05	H5 ±0.05	H6 ±0.05	H7 ±0.05	H8 ±0.05	H9	H10
16	3.4	100	98	75	–	50	30	30	50	30.7	10
25	–	120	118	90	70	50	33	40	60	40.7	14
40	–	135	133	105	80	60	40	40	70	55.7	18

Size	L1	L2	L3 ±0.05	L4	L5 ±0.05	L6	L7 ±0.05	L8	L9 ±0.1	T1	T2 +0.1
16	109 + stroke	75	40	34	20	51	50	12	63	–	2.1
25	124 + stroke	85	50	40	25	59	60	15	–	5.5	2.1
40	151 + stroke	105	70	48	35	72	70	18	–	5.5	2.1

Size	T3	T4 +0.1	T5 +0.1	T6	T7 +0.1	T8 +0.1	T9	T10 +0.1	T11	T12 +0.1	T13 ±1	T14
16	15.5	2.1	2.1	6.5	1.6	1.6	8.5 _{-0.5}	2.1	4.4	1.6	–	31.5
25	14	2.1	2.1	6.4	2.1	1.6	Min. 10	2.1	5.7	1.6	12.5	–
40	12	2.1	2.1	7.3	2.1	1.6	Min. 10	2.1	5.5	1.6	15.5	–

Guide units EAGF, for electric cylinders EPCO

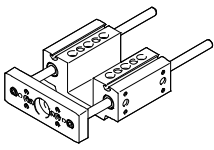

Technical data

★ Core product range

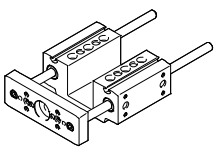
Ordering data				
Guide unit	Size	Stroke [mm]	Part No.	Type
	16	50	★ 3192932	EAGF-P1-KF-16-50
		100	★ 3192934	EAGF-P1-KF-16-100
		150	★ 3192936	EAGF-P1-KF-16-150
		200	★ 3192938	EAGF-P1-KF-16-200
	25	50	★ 3192943	EAGF-P1-KF-25-50
		100	★ 3192945	EAGF-P1-KF-25-100
		150	★ 3192947	EAGF-P1-KF-25-150
		200	★ 3192949	EAGF-P1-KF-25-200
		300	★ 3192951	EAGF-P1-KF-25-300
	40	50	★ 3192955	EAGF-P1-KF-40-50
		100	★ 3192957	EAGF-P1-KF-40-100
		150	★ 3192959	EAGF-P1-KF-40-150
200		★ 3192961	EAGF-P1-KF-40-200	
300		★ 3192963	EAGF-P1-KF-40-300	

Ordering data				
Guide unit	Size	Stroke [mm]	Part No.	Type
	16	75, 125, 175	3192939	EAGF-P1-KF-16-
	25	75, 125, 175, 250	3192952	EAGF-P1-KF-25-
	40	75, 125, 175, 250 350, 400	3192966	EAGF-P1-KF-40-

Accessories

Ordering data					
	For size	Description	Part No.	Type	PU ¹⁾
Centring sleeve					
	16, 25, 40	For centring the drive or attachments	186717	ZBH-7	10
			150927	ZBH-9	
Connector sleeve					
	16	For centring the drive or attachments	548805	ZBV-9-7	10

1) Packaging unit

Festo core product range

- ★ Ready for dispatch from the Festo factory in 24 hours
- ★ Ready for dispatch in 5 days maximum from stock

Festo North America

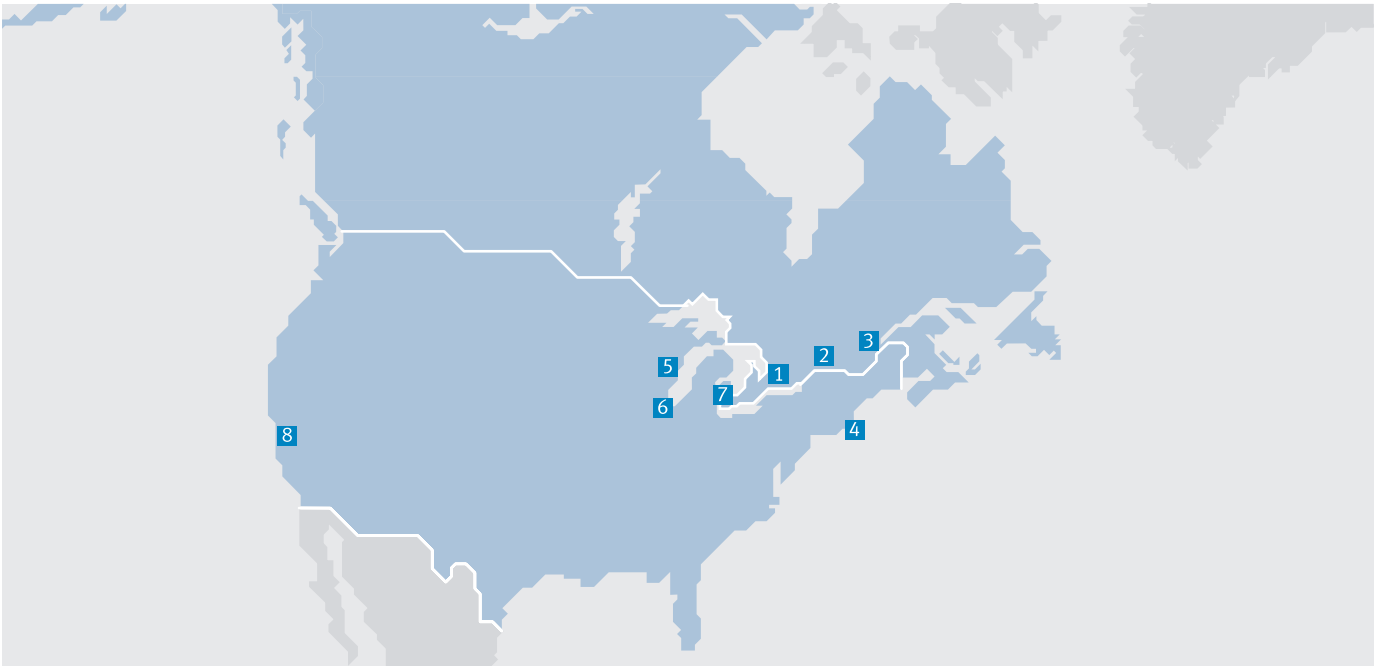

**1 Festo Canada
Headquarters
Festo Inc.**
5300 Explorer Drive
Mississauga, ON
L4W 5G4

2 Montréal
5600, Trans-Canada
Pointe-Claire, QC
H9R 1B6

3 Québec City
2930, rue Watt#117
Québec, QC
G1X 4G3



**4 Festo United States
Headquarters
Festo Corporation**
395 Moreland Road
Hauppauge, NY
11788

5 Appleton
North 922 Tower View Drive, Suite N
Greenville, WI
54942

7 Detroit
1441 West Long Lake Road
Troy, MI
48098

6 Chicago
85 W Algonquin - Suite 340
Arlington Heights, IL
60005

8 Silicon Valley
4935 Southfront Road, Suite F
Livermore, CA
94550

Festo Regional Contact Center

Canadian Customers

Commercial Support:
Tel: 1 877 GO FESTO (1 877 463 3786)
Fax: 1 877 FX FESTO (1 877 393 3786)
Email: festo.canada@ca.festo.com

Technical Support:
Tel: 1 866 GO FESTO (1 866 463 3786)
Fax: 1 877 FX FESTO (1 877 393 3786)
Email: technical.support@ca.festo.com

USA Customers

Commercial Support:
Tel: 1 800 99 FESTO (1 800 993 3786)
Fax: 1 800 96 FESTO (1 800 963 3786)
Email: customer.service@us.festo.com

Technical Support:
Tel: 1 866 GO FESTO (1 866 463 3786)
Fax: 1 800 96 FESTO (1 800 963 3786)
Email: product.support@us.festo.com

Subject to change

Internet: www.festo.com/us